

# Specification for Approval

Date: 2016/1/5

Customer : \_\_\_\_\_

TAI-TECH P/N: FCM-F-Series

CUSTOMER P/N: \_\_\_\_\_

DESCRIPTION: Ferrite Chip Bead

QUANTITY: \_\_\_\_\_ pcs

REMARK:		
Customer Approval Feedback		

Sales Dep.

APPROVED	CHECKED
Jim Wu	Yan Zhong

R&D Center

APPROVED	CHECKED	DRAWN
James Chung	Joe Chou	Alice Hsu

# Ferrite Chip Bead(Lead Free) FCM-F-Series

## 1.Features

- 1.Monolithic inorganic material construction.
- 2.Closed magnetic circuit avoids crosstalk.
- 3.S.M.T. type.
- 4.Suitable for flow and reflow soldering.
- 5.Shapes and dimensions follow E.I.A. spec.
- 6.Available in various sizes.
- 7.Excellent solderability and heat resistance.
- 8.High reliability.
- 9.This component is compliant with RoHS legislation and also support lead-free soldering.

## 2.Dimensions

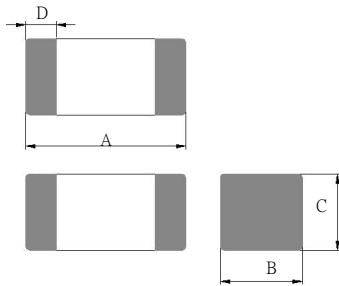

Chip size				
Size	A(mm)	B(mm)	C(mm)	D(mm)
1005	1.0±0.10	0.50±0.10	0.50±0.10	0.25±0.1
1608	1.6±0.15	0.80±0.15	0.80±0.15	0.30±0.2
2012	2.0±0.20	1.25±0.20	0.85±0.20	0.50±0.3
			1.25±0.20	
3216	3.2±0.20	1.60±0.20	1.10±0.20	0.50±0.3

## 3.Part Numbering



- A: Series
- B: Dimension L x W
- C: Material Lead Free Material
- D: Impedance 121=120Ω
- E: Packaging T=Taping and Reel, B=Bulk(Bags)
- F: Rated Current 01=100mA

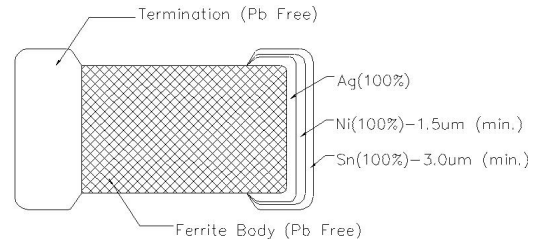

## 4.Specification

Tai-Tech Part Number	Impedance (Ω)	Test Frequency (MHz)	DC Resistance (Ω) max.	Rated Current (mA)
<a href="#">FCM1005KF-300T03</a>	30±25%	100	0.20	300
<a href="#">FCM1005KF-600T03</a>	60±25%	100	0.25	300
<a href="#">FCM1005KF-121T01</a>	120±25%	100	0.30	100
<a href="#">FCM1005KF-151T01</a>	150±25%	100	0.30	100
<a href="#">FCM1005KF-221T01</a>	220±25%	100	0.40	100
<a href="#">FCM1005KF-301T01</a>	300±25%	100	0.50	100
<a href="#">FCM1005KF-471T01</a>	470±25%	100	0.65	100
<a href="#">FCM1005KF-601T00</a>	600±25%	100	0.80	80
<a href="#">FCM1005MF-600T01</a>	60±25%	100	0.30	100
<a href="#">FCM1005MF-121T00</a>	120±25%	100	0.45	80
<a href="#">FCM1005MF-221T00</a>	220±25%	100	0.60	50
<a href="#">FCM1005MF-301T00</a>	300±25%	100	0.75	50

Tai-Tech Part Number	Impedance ( $\Omega$ )	Test Frequency (MHz)	DC Resistance ( $\Omega$ ) max.	Rated Current (mA)
FCM1608KF-600T07	60±25%	100	0.20	700
FCM1608KF-121T06	120±25%	100	0.25	600
FCM1608KF-151T06	150±25%	100	0.25	600
FCM1608KF-221T05	220±25%	100	0.30	550
FCM1608KF-301T05	300±25%	100	0.35	500
FCM1608KF-471T03	470±25%	100	0.45	350
FCM1608KF-601T03	600±25%	100	0.50	350
FCM1608KF-102T02	1000±25%	100	0.70	200
FCM1608HF-152T02	1500±25%	100	1.00	200
FCM1608HF-202T01	2000±25%	100	1.20	150
FCM1608CF-300T06	30±25%	100	0.25	600
FCM1608CF-600T06	60±25%	100	0.30	600
FCM1608CF-800T04	80±25%	100	0.30	400
FCM1608CF-121T03	120±25%	100	0.40	300
FCM1608CF-151T03	150±25%	100	0.40	300
FCM1608CF-221T02	220±25%	100	0.60	250
FCM1608CF-301T02	300±25%	100	0.80	200
FCM1608CF-471T02	470±25%	100	0.85	200
FCM1608CF-601T01	600±25%	100	1.20	150
FCM1608CF-102T00	1000±25%	100	1.50	80
FCM1608WF-121T03	120±25%	100	0.25	300
FCM1608WF-151T02	150±25%	100	0.30	250
FCM1608WF-221T02	220±25%	100	0.35	200
FCM1608WF-301T02	300±25%	100	0.45	250
FCM1608WF-471T02	470±25%	100	0.55	200
FCM1608WF-601T02	600±25%	100	0.70	200
FCM1608WF-801T01	800±25%	100	0.80	100
FCM1608WF-102T01	1000±25%	100	0.90	100
FCM2012KF-600T09	60±25%	100	0.10	900
FCM2012KF-121T08	120±25%	100	0.20	800
FCM2012KF-151T08	150±25%	100	0.20	800
FCM2012KF-221T07	220±25%	100	0.30	750
FCM2012KF-301T07	300±25%	100	0.30	700
FCM2012KF-471T07	470±25%	100	0.35	700
FCM2012KF-601T05	600±25%	100	0.40	500
FCM2012KF-801T04	800±25%	100	0.40	450
FCM2012KF-102T04	1000±25%	100	0.45	400
FCM2012HF-102T04	1000±25%	100	0.45	400
FCM2012HF-152T03	1500±25%	100	0.50	350
FCM2012HF-202T02	2000±25%	100	0.60	250
FCM2012HF-232T02	2300±25%	100	0.80	200
FCM2012HF-272T01	2700±25%	100	1.1	150
FCM2012CF-300T07	30±25%	100	0.20	700
FCM2012CF-600T07	60±25%	100	0.20	700
FCM2012CF-121T06	120±25%	100	0.25	600
FCM2012CF-151T06	150±25%	100	0.25	600
FCM2012CF-221T04	220±25%	100	0.30	400

**TAI-TECH**

Tai-Tech Part Number	Impedance ( $\Omega$ )	Test Frequency (MHz)	DC Resistance ( $\Omega$ ) max.	Rated Current (mA)
FCM2012CF-301T04	300 $\pm$ 25%	100	0.35	400
FCM2012CF-471T04	470 $\pm$ 25%	100	0.40	400
FCM2012CF-601T03	600 $\pm$ 25%	100	0.45	300
FCM2012CF-102T02	1000 $\pm$ 25%	100	0.50	200
FCM2012WF-121T03	120 $\pm$ 25%	100	0.15	300
FCM2012WF-151T03	150 $\pm$ 25%	100	0.20	300
FCM2012WF-221T02	220 $\pm$ 25%	100	0.30	250
FCM2012WF-301T02	300 $\pm$ 25%	100	0.35	200
FCM2012WF-471T02	470 $\pm$ 25%	100	0.40	200
FCM2012WF-601T02	600 $\pm$ 25%	100	0.45	200
FCM2012WF-801T01	800 $\pm$ 25%	100	0.55	150
FCM2012WF-102T01	1000 $\pm$ 25%	100	0.65	100
FCM3216KF-121T09	120 $\pm$ 25%	100	0.15	900
FCM3216KF-151T09	150 $\pm$ 25%	100	0.15	900
FCM3216KF-221T07	220 $\pm$ 25%	100	0.35	700
FCM3216KF-301T07	300 $\pm$ 25%	100	0.35	700
FCM3216KF-471T04	470 $\pm$ 25%	100	0.35	400
FCM3216KF-601T04	600 $\pm$ 25%	100	0.40	400
FCM3216KF-801T03	800 $\pm$ 25%	100	0.60	300
FCM3216KF-102T03	1000 $\pm$ 25%	100	0.60	300
FCM3216VF-152T03	1500 $\pm$ 25%	50	0.70	300
FCM3216VF-202T03	2000 $\pm$ 25%	30	0.70	300
FCM3216CF-121T07	120 $\pm$ 25%	100	0.25	700
FCM3216CF-151T07	150 $\pm$ 25%	100	0.25	700
FCM3216CF-221T06	220 $\pm$ 25%	100	0.30	600
FCM3216CF-301T06	300 $\pm$ 25%	100	0.35	600
FCM3216CF-121T07	120 $\pm$ 25%	100	0.25	700
FCM3216CF-151T07	150 $\pm$ 25%	100	0.25	700
FCM3216CF-221T06	220 $\pm$ 25%	100	0.30	600
FCM3216CF-301T06	300 $\pm$ 25%	100	0.35	600
FCM3216CF-121T07	120 $\pm$ 25%	100	0.25	700
FCM3216CF-151T07	150 $\pm$ 25%	100	0.25	700
FCM3216CF-221T06	220 $\pm$ 25%	100	0.30	600
FCM3216CF-301T06	300 $\pm$ 25%	100	0.35	600
FCM3216CF-121T07	120 $\pm$ 25%	100	0.25	700
FCM3216CF-151T07	150 $\pm$ 25%	100	0.25	700
FCM3216CF-221T06	220 $\pm$ 25%	100	0.30	600
FCM3216CF-301T06	300 $\pm$ 25%	100	0.35	600
FCM3216CF-121T07	120 $\pm$ 25%	100	0.25	700
FCM3216CF-151T07	150 $\pm$ 25%	100	0.25	700

### 5. Reliability and Test Condition

Item	Performance										Test Condition																																	
	Series No.	FCB	FCM	HCB	HPB	HFB	FCA	FCI	FHI	FCH		HCI																																
Operating Temperature	-55~+125℃					-40~+85℃					--																																	
Storage Temperature	-55~+125℃					-40~+85℃					--																																	
Impedance (Z)	Refer to standard electrical characteristics list										HP4291A, HP4287A+16092A																																	
Inductance (Ls)																																												
Q Factor																																												
DC Resistance											HP4338B																																	
Rated Current											**																																	
Temperature Rise Test	30℃ max. ( T )										1. Applied the allowed DC current. 2. Temperature measured by digital surface thermometer.																																	
Solder heat Resistance	Appearance: No significant abnormality. Impedance change: Within ± 30%.				No mechanical damage. Remaining terminal electrode:70% min.				Preheat: 150℃,60sec. Solder: Sn-Ag3.0-Cu0.5 Solder temperature: 260±5℃ Flux for lead free: rosin Dip time: 10±0.5sec.																																			
Solderability	More than 90% of the terminal electrode should be covered with solder.								Preheat: 150℃,60sec. Solder: Sn-Ag3.0-Cu0.5 Solder temperature: 230±5℃ Flux for lead free: rosin Dip time: 4±1sec.																																			
Terminal strength	The terminal electrode and the dielectric must not be damaged by the forces applied on the right conditions.								For FCB FCM HCB HPB HFB FCI FHI FCH HCI: <table border="1"> <thead> <tr> <th>Size</th> <th>Force (Kgf)</th> <th>Time(sec)</th> </tr> </thead> <tbody> <tr><td>1005</td><td>0.2</td><td></td></tr> <tr><td>1608</td><td>0.5</td><td></td></tr> <tr><td>2012</td><td>0.6</td><td></td></tr> <tr><td>3216</td><td>1.0</td><td>&gt;25</td></tr> <tr><td>3225</td><td>1.0</td><td></td></tr> <tr><td>4516</td><td>1.0</td><td></td></tr> <tr><td>4532</td><td>1.5</td><td></td></tr> <tr><td>5750</td><td>2.0</td><td></td></tr> </tbody> </table> For FCA: <table border="1"> <thead> <tr> <th>Size</th> <th>Force (Kgf)</th> <th>Time(sec)</th> </tr> </thead> <tbody> <tr><td>3216</td><td>0.5</td><td>&gt;25</td></tr> </tbody> </table>			Size	Force (Kgf)	Time(sec)	1005	0.2		1608	0.5		2012	0.6		3216	1.0	>25	3225	1.0		4516	1.0		4532	1.5		5750	2.0		Size	Force (Kgf)	Time(sec)	3216	0.5	>25
Size	Force (Kgf)	Time(sec)																																										
1005	0.2																																											
1608	0.5																																											
2012	0.6																																											
3216	1.0	>25																																										
3225	1.0																																											
4516	1.0																																											
4532	1.5																																											
5750	2.0																																											
Size	Force (Kgf)	Time(sec)																																										
3216	0.5	>25																																										
Flexure strength	The terminal electrode and the dielectric must not be damaged by the forces applied on the right conditions.								Solder a chip on a test substrate, bend the substrate by 2mm (0.079in)and return.																																			
Bending Strength	The ferrite should not be damaged by Forces applied on the right condition.								<table border="1"> <thead> <tr> <th>Size</th> <th>mm(inches)</th> <th>P-Kgf</th> </tr> </thead> <tbody> <tr><td>1608</td><td>0.80(0.033)</td><td>0.3</td></tr> <tr><td>2012</td><td>1.40(0.055)</td><td>1.0</td></tr> <tr><td>FCA3216</td><td>2.00(0.079)</td><td>1.5</td></tr> <tr><td>3216</td><td>2.00(0.079)</td><td>2.5</td></tr> <tr><td>3225</td><td>2.00(0.079)</td><td>2.5</td></tr> <tr><td>4516</td><td></td><td></td></tr> <tr><td>4532</td><td>2.70(0.106)</td><td>2.5</td></tr> <tr><td>5750</td><td></td><td></td></tr> </tbody> </table>			Size	mm(inches)	P-Kgf	1608	0.80(0.033)	0.3	2012	1.40(0.055)	1.0	FCA3216	2.00(0.079)	1.5	3216	2.00(0.079)	2.5	3225	2.00(0.079)	2.5	4516			4532	2.70(0.106)	2.5	5750								
Size	mm(inches)	P-Kgf																																										
1608	0.80(0.033)	0.3																																										
2012	1.40(0.055)	1.0																																										
FCA3216	2.00(0.079)	1.5																																										
3216	2.00(0.079)	2.5																																										
3225	2.00(0.079)	2.5																																										
4516																																												
4532	2.70(0.106)	2.5																																										
5750																																												
Random Vibration Test	Appearance: Cracking, shipping and any other defects harmful to the characteristics should not be allowed. Impedance: within±30%										Frequency: 10-55-10Hz for 1 min. Amplitude: 1.52mm Directions and times: X, Y, Z directions for 2 hours. A period of 2 hours in each of 3 mutually perpendicular directions (Total 6 hours).																																	
Drop	Drop 10 times on a concrete floor from a height of 75cm										a: No mechanical damage b: Impedance change: ±30%																																	

Item	Performance	Test Condition
Loading at High Temperature	Appearance: no damage.	Temperature: 125±5°C (bead), 85±5°C (inductor) Applied current: rated current. Duration: 500±12hrs. Measured at room temperature after placing for 2 to 3hrs.
Humidity	Impedance: within±30%of initial value. Inductance: within±10%of initial value. Q: within±30%of initial value. (FCI FHI FCH) Q: within±20%of initial value. (HCI)	Humidity: 90~95%RH. Temperature: 40±2°C. Temperature: 60±2°C.(HCI) Duration: 500±12hrs. Measured at room temperature after placing for 2 to 3hrs.
Thermal shock	Appearance: no damage. Impedance: within±30%of initial value. Inductance: within±10%of initial value. Q: within±30%of initial value. (FCI FHI FCH) Q: within±20%of initial value. (HCI)	For FCB FCM HCB HPB HFB FCA : Condition for 1 cycle Step1: -55±2°C 30±3 min. Step2: +125±5°C 30±3 min. Number of cycles: 5 For FCI FHI FCH HCI : Condition for 1 cycle Step1: -40±2°C 30±3 min. Step2: +85±5°C 30±3 min. Number of cycles: 100 Measured at room temperature after placing for 2 to 3 hrs.
Low temperature storage test	Measured: 5 times Measured: 100 times	Temperature: -55±2°C. Duration: 500±12hrs. Measured at room temperature after placing for 2 to 3hrs.
Drop	Drop 10 times on a concrete floor from a height of 75cm	a: No mechanical damage b: Impedance change: ±30%

**\*\*Derating Curve**

For the ferrite chip bead which withstanding current over 1.5A, as the operating temperature over 85°C, the derating current information is necessary to consider with. For the detail derating of current, please refer to the Derated Current vs. Operating Temperature curve.

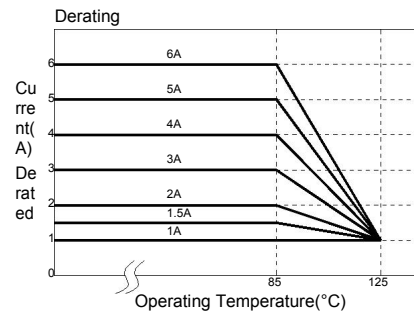

**6.Soldering and Mounting**

**6-1. Recommended PC Board Pattern**

Series	Type	Chip Size				Land Patterns For Reflow Soldering		
		A(mm)	B(mm)	C(mm)	D(mm)	L(mm)	G(mm)	H(mm)
FCB	1005	1.0±0.10	0.50±0.10	0.50±0.10	0.25±0.10	2.10	0.50	0.55
FCM	1608	1.6±0.15	0.80±0.15	0.80±0.15	0.30±0.20	2.60	0.60	0.80
HCB	2012	2.0±0.20	1.25±0.20	0.85±0.20	0.50±0.30	3.00	1.00	1.00
HPB		2.0±0.20	1.25±0.20	1.25±0.20	0.50±0.30			
HFB	2520	2.5±0.20	2.00±0.20	1.60±0.20	0.50±0.30	3.90	1.50	1.50
FCI	3216	3.2±0.20	1.60±0.20	1.10±0.20	0.50±0.30	4.40	2.20	1.40
FHI	3225	3.2±0.20	2.50±0.20	1.30±0.20	0.50±0.30	4.40	2.20	3.40
FCH	4516	4.5±0.20	1.60±0.20	1.60±0.20	0.50±0.30	5.70	2.70	1.40
HCI	4532	4.5±0.20	3.20±0.20	1.50±0.20	0.50±0.30	5.90	2.57	4.22
UHI	5750	5.7±0.20	5.00±0.30	1.80±0.20	0.50±0.30	8.00	4.00	5.80

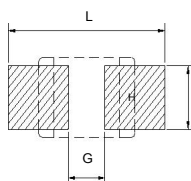
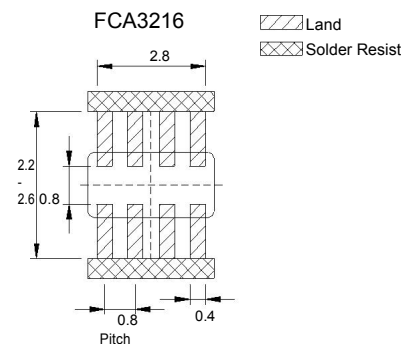

PC board should be designed so that products are not sufficient under mechanical stress as warping the board. Products shall be positioned in the sideways direction against the mechanical stress to prevent failure.

**6-2. Soldering**

Mildly activated rosin fluxes are preferred. The minimum amount of solder can lead to damage from the stresses caused by the difference in coefficients of expansion between solder, chip and substrate. The terminations are suitable for all wave and re-flow soldering systems. If hand soldering cannot be avoided, the preferred technique is the utilization of hot air soldering tools.

**6-2.1 Lead Free Solder re-flow:**

Recommended temperature profiles for lead free re-flow soldering in Figure 1.

**6-2.2 Solder Wave:**

Wave soldering is perhaps the most rigorous of surface mount soldering processes due to the steep rise in temperature seen by the circuit when immersed in the molten solder wave, typical at 230°C. Due to the risk of thermal damage to products, wave soldering of large size products is discouraged. Recommended temperature profile for wave soldering is shown in Figure 2.

**6-2.3 Soldering Iron(Figure 3):**

Products attachment with a soldering iron is discouraged due to the inherent process control limitations. In the event that a soldering iron must be employed the following precautions are recommended.

- Note :
- Preheat circuit and products to 150°C
  - Never contact the ceramic with the iron tip
  - Use a 20 watt soldering iron with tip diameter of 1.0mm
  - 350°C tip temperature for Ferrite chip bead (max)
  - 1.0mm tip diameter (max)
  - Limit soldering time to 3 sec.

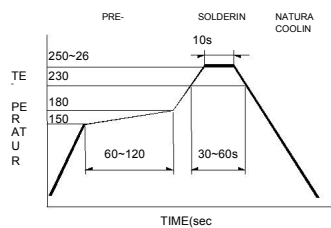

Figure 1. Re-flow Soldering(Lead Free)

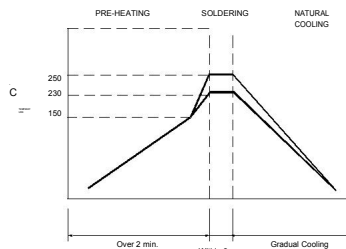

Figure 2. Wave Soldering

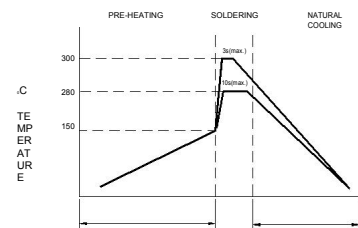
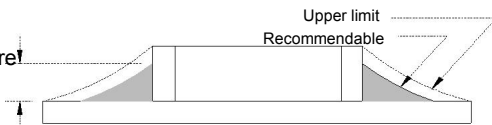

Figure 3. Hand Soldering

**6-2.4 Solder Volume:**

Accordingly increasing the solder volume, the mechanical stress to product is also increased. Exceeding solder volume may cause the failure of mechanical or electrical performance. Solder shall be used not to be exceed as shown in right side:



**7. Packaging Information**

**7-1. Reel Dimension**

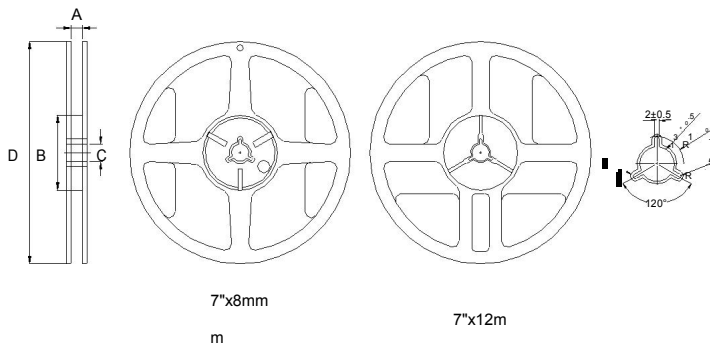

Type	A(mm)	B(mm)	C(mm)	D(mm)
7"x8mm	9.0±0.5	60±2	13.5±0.5	178±2
7"x12mm	13.5±0.5	60±2	13.5±0.5	178±2

**7-2.1 Tape Dimension / 8mm**

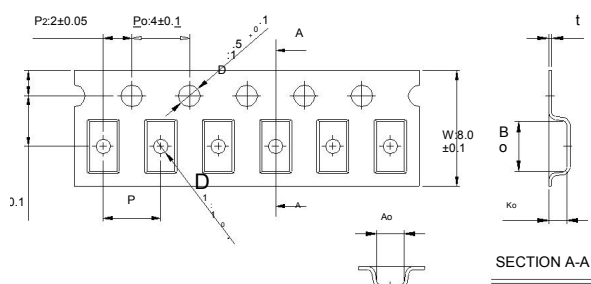

Series	Size	Bo(mm)	Ao(mm)	Ko(mm)	P(mm)	t(mm)	D1(mm)
FCB,FCM	100505	1.12±0.05	0.67±0.05	0.54±0.05	2.0±0.1	0.23±0.05	none
HCB,HPB	160808	1.80±0.10	1.01±0.10	1.02±0.10	4.0±0.1	0.22±0.05	none
HFB	201209	2.25±0.10	1.42±0.10	1.04±0.10	4.0±0.1	0.22±0.05	1.0±0.1
FCI	201212	2.35±0.10	1.50±0.10	1.45±0.10	4.0±0.1	0.22±0.05	1.0±0.1
FHI, FCH	321611	3.50±0.10	1.88±0.10	1.27±0.10	4.0±0.1	0.22±0.05	1.0±0.1
HCI	322513	3.42±0.10	2.77±0.10	1.55±0.10	4.0±0.1	0.22±0.05	1.0±0.1
FCA	321609	3.40±0.10	1.77±0.10	1.04±0.1	4.0±0.10	0.22±0.05	1.0±0.1

7-2.2 Tape Dimension / 12mm

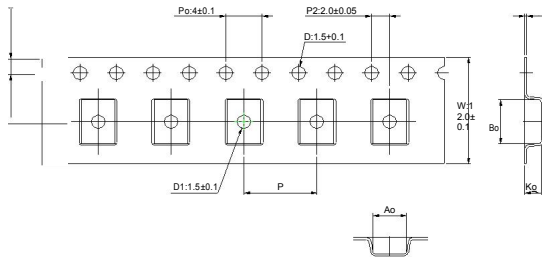

Series	Size	Bo(mm)	Ao(mm)	Ko(mm)	P(mm)	t(mm)	D1(mm)
FCB,	451616	4.95±0.1	1.93±0.1	1.93±0.1	4.0±0.1	0.24±0.05	1.5±0.1
HC.B.FCM	453215	4.95±0.1	3.66±0.1	1.85±0.1	8.0±0.1	0.24±0.05	1.5±0.1
FCI	575018	6.10±0.1	5.40±0.1	2.00±0.1	8.0±0.1	0.30±0.05	1.5±0.1

7-3. Packaging Quantity

Chip Size	575018	453215	451616	322513	321611	201212	201209	160808	100505
Chip / Reel	1000	1000	2000	2500	3000	2000	4000	4000	10000
Inner box	4000	4000	8000	12500	15000	10000	20000	20000	50000
Middle box	20000	20000	40000	62500	75000	50000	100000	100000	250000
Carton	40000	40000	80000	125000	150000	100000	200000	200000	500000
Bulk (Bags)	7000	12000	20000	30000	50000	100000	150000	200000	300000

7-4. Tearing Off Force

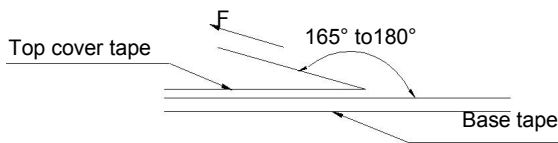

The force for tearing off cover tape is 15 to 60 grams in the arrow direction under the following conditions.

5~35	45~85	860~1060	300

**Application Notice**

• Storage Conditions

To maintain the solderability of terminal electrodes:

1. Temperature and humidity conditions: -10~ 40°C and 30~70% RH.
2. Recommended products should be used within 6 months from the time of delivery.
3. The packaging material should be kept where no chlorine or sulfur exists in the air.

• Transportation

1. Products should be handled with care to avoid damage or contamination from perspiration and skin oils.
2. The use of tweezers or vacuum pick up is strongly recommended for individual components.
3. Bulk handling should ensure that abrasion and mechanical shock are minimized.



## Impedance Frequency Characteristics(Typical)

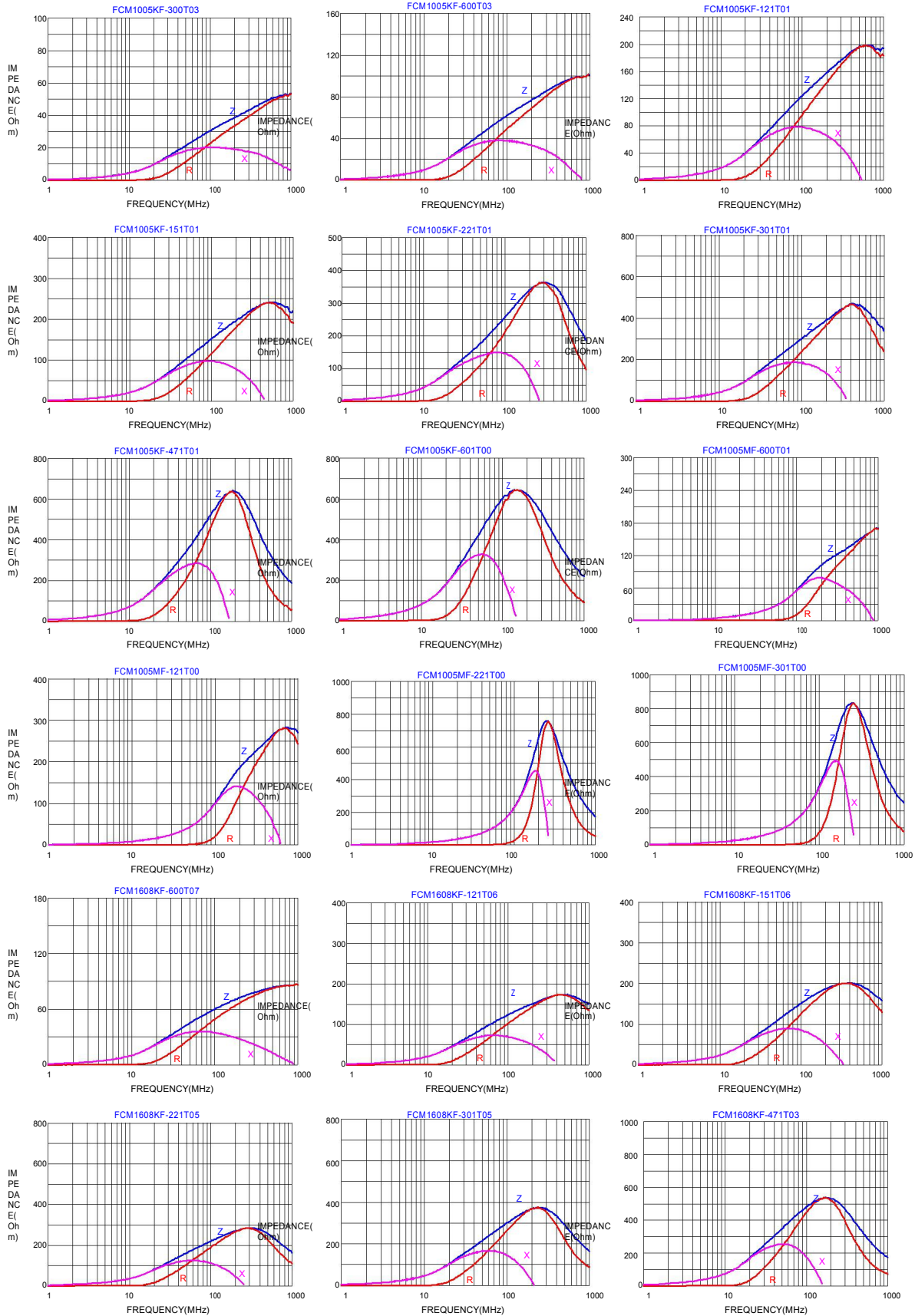

## Impedance Frequency Characteristics(Typical)

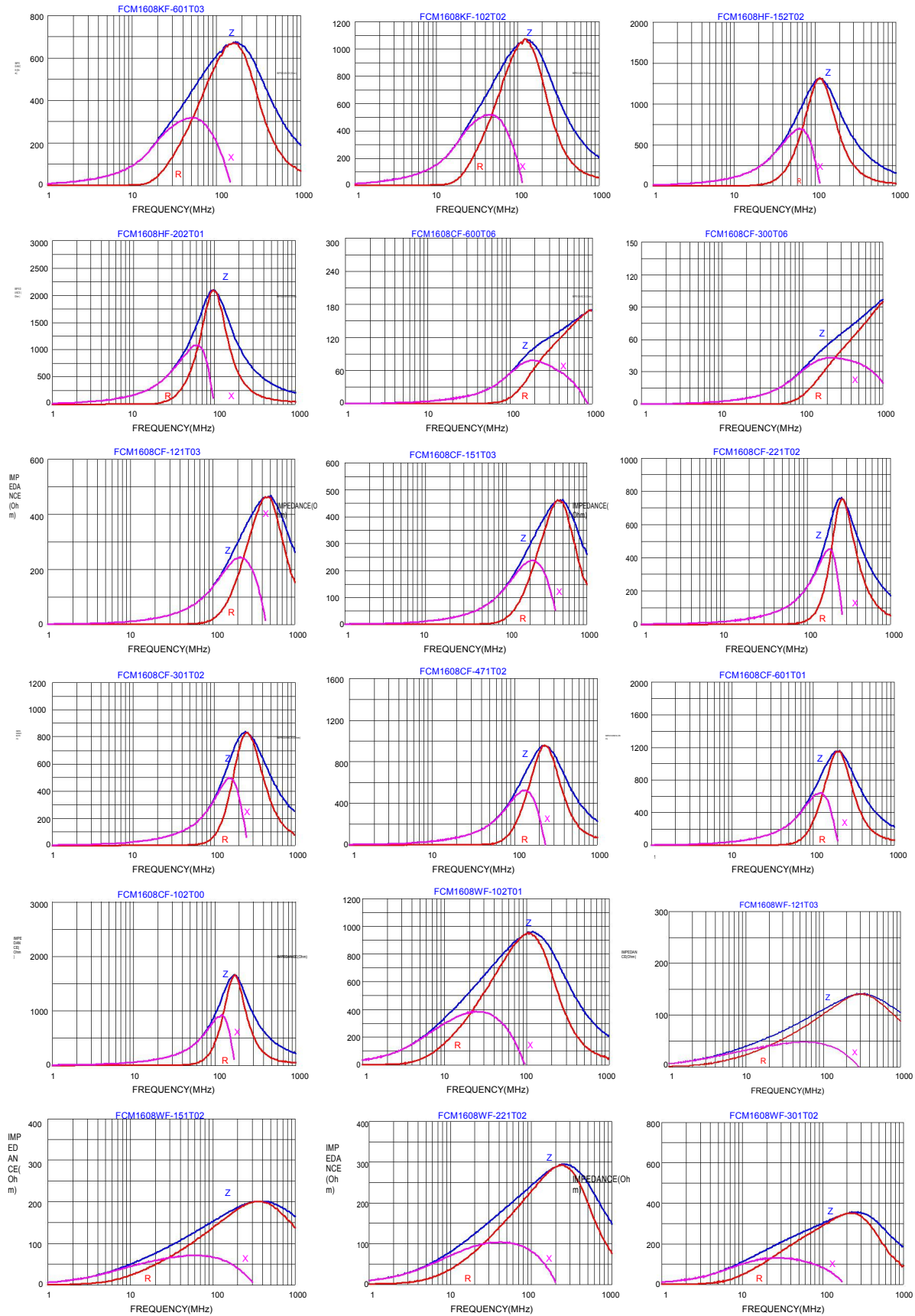

## Impedance Frequency Characteristics(Typical)

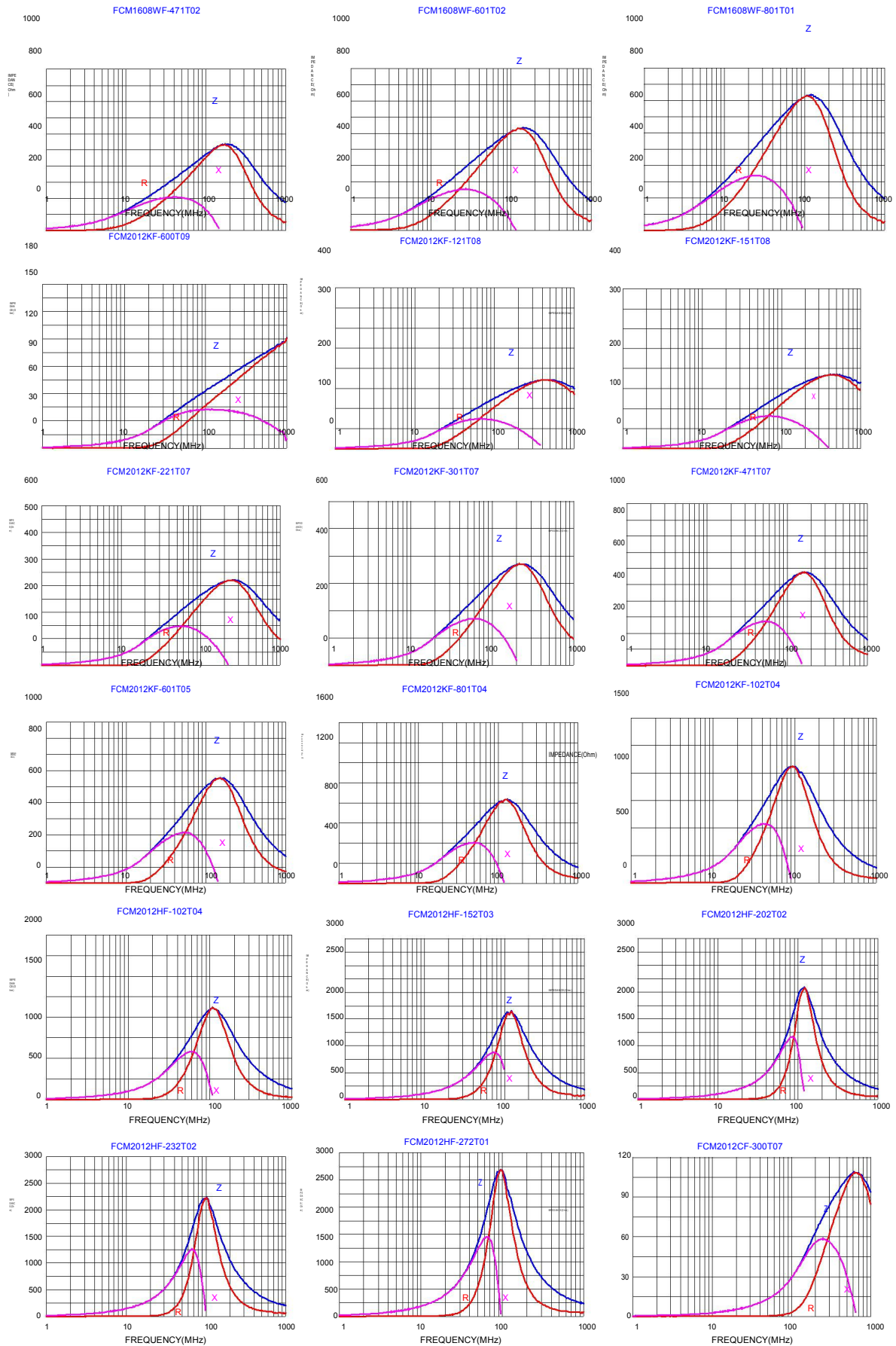

## Impedance Frequency Characteristics(Typical)

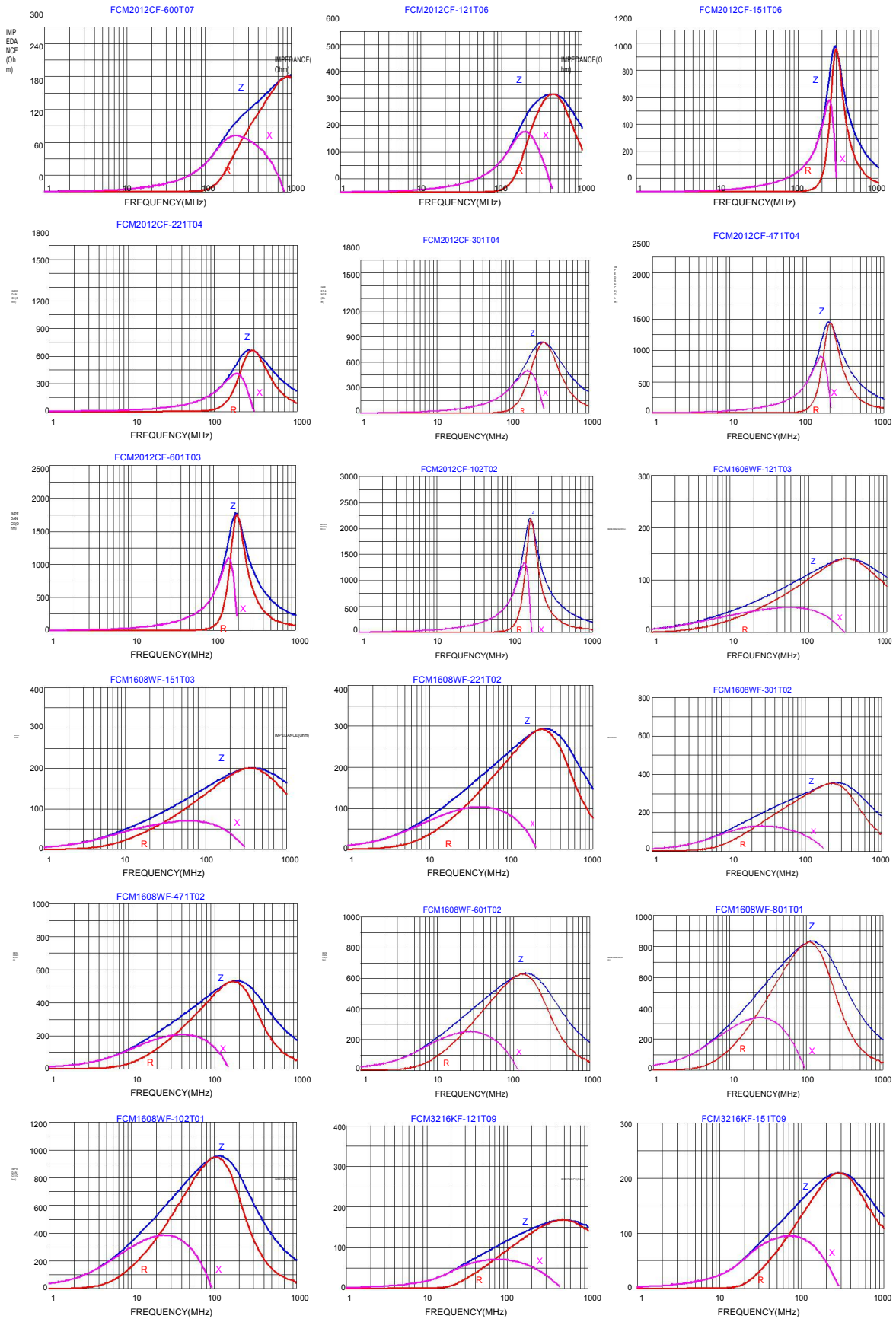

## Impedance Frequency Characteristics(Typical)

